

RG-03M Resonator Guitar Pickup & Condenser Mic System For Spider Bridged Instruments

The M microphone in the RG-03M system was designed to add air, clarity and sound quality to the normal attributes of the RG-03 pickup sensor. The M microphone was not designed to be, nor is it intended to be used as a stand-alone microphone.

Important: Please read these instruction through first before installing this system.

Starting Installation

1) Slack off the strings, remove them from the tailpiece and tape them away from the cover plate. Remove the cover plate screws and set the cover plate aside. Remove the tailpiece and resonator cone complete with the spider bridge and set the rest of the guitar aside.

2) Remove the screw that connects the spider bridge to the resonator cone. There are two replacement screws provided, one is a 3 mm. metric, the other is a 4-40. Check to see which of the two screws fits your resonator cone properly. The correct screw should thread in very easily, do not force it. Also, make sure that the head of the replacement screw fits into the saddle slot properly. If the screw head is too large to fit in the slot, grind off or file away whatever small amount of the head diameter is necessary to make it fit in the slot properly. Once the screw is properly fitted, use it to snugly attach the spider to the cone.

3) It is suggested that at this point you reinstall the cone with the spider and saddles into the instrument (leave the cover plate off), reinstall the strings, tune the instrument and tighten the machine screw that connects the spider to the cone so that the sound and response is set to original levels. When this is done, remove the strings, set the cone and spider assembly on your workbench and set the rest of the instrument aside.

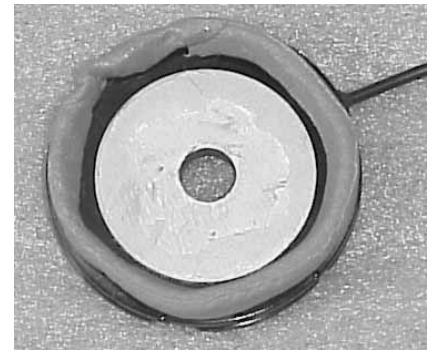
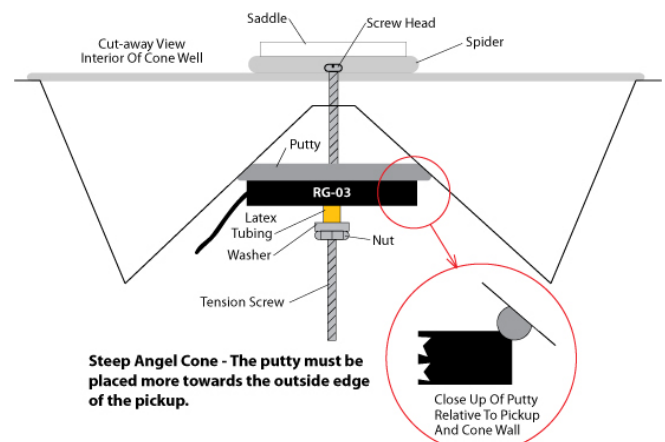
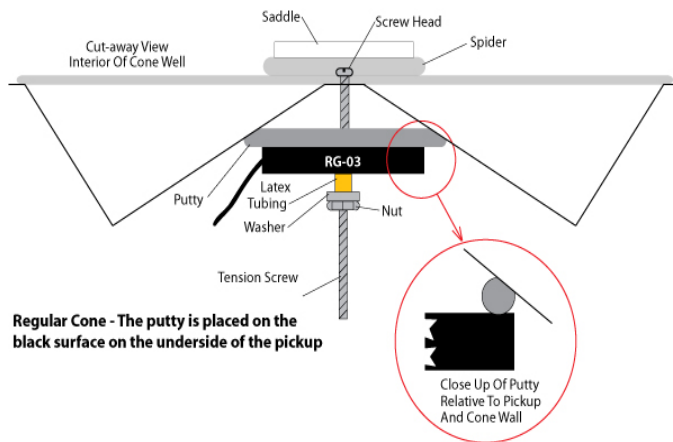

fig 1

Installing the Pickup Element

The RG-03 sensor is not meant to come into direct contact with any part of the cone. The putty that is supplied with the pickup acts as both a means of attachment and as an isolator; there always has to be a bead of putty between the contacting surface of the sensor and the wall of the resonator cone. The sensor is meant to contact the sidewall of the only.

1) Place the pickup on your work surface with the brass side facing up. From the supply of putty provided, run a single bead around the outside of the diameter of the brass so that the putty covers only the black colored potting material outboard of the brass. This bead should be about 1/4" in diameter. If possible, no putty should be on the brass surface. *See fig 1* Note: On some cones, such as a Quarterman, the cone has a much steeper slope than is normal. In order for the pickup to not come into direct contact with the cone, the putty must be moved further outboard than normal so that it is partly on the edge of the pickup and partly on the underside. See illustrations below:



2) Place the small length of rubber tubing over the already installed cone mounting screw. Slide the tubing down as close to the cone as you can. The tubing has two functions: it acts as a damper and it isolates the pickup from coming into contact with the mounting screw.

3) With the putty and brass side towards the cone, install the pickup by centering the pickup over the mounting screw and sliding the pickup over the rubber tubing and just allowing the putty to come into contact with the underside of the cone.

4) The rubber tubing is supplied longer than is necessary so that it will fit all installations. We want the tubing to stick up above the pickup by about 1/8". Take a pen and draw a line on the tubing at a point 1/8" above the top of the pickup. Remove the tubing and cut on that line. Reinstall the tubing on the mounting screw making sure to get it down as close to the bottom of the mounting screw as before. Reinstall the pickup. See *fig 2*

5) Place the small washer, and then the appropriate nut on the cone mounting screw. Tighten the nut down until the putty starts to compress. Then tighten the nut down another 2 or 3 turns. Over compression of the putty or allowing the pickup itself to come into contact with the cone surface will make the pickup trebly and extremely harsh.



fig 2

M Condenser Microphone Installation:

1) The suggested mounting position for the microphone is as shown, just below the cut for the lip of the cone. The mic will be generally be placed 3/8" down from that cut.

2) Both putty and 3M VHB mounting tape is supplied for installing the microphone. The suggested method of mounting the mic is to use the supplied putty.

3) Roll up a small ball of the putty (about 3/8" in diameter) and spread it out evenly on the flat surface of the microphone mount. Press the microphone mount firmly against the side wall of the well. It may be necessary to press the assembly against the wall several times over ten or fifteen minutes until the putty takes a set.

4) If the wall surface is clean and smooth, the VHB may be used for mounting if desired. Alternatively, a small screw may be used to affix the mic to the wall using the small hole in the mount.



Installing the Jack

Note: You have the option of permanently installing the supplied jack as an endpin jack, as a side jack or, if you don't wish to drill a hole through the butt or side of the instrument, the jack may be hung from an existing tailpiece screw or strap button.

For endpin jack use

1) Remove the existing strap button. If the strap button screw also functioned to hold the tailpiece in place, then reinstall the screw without the strap button.

2) Measure the actual depth of your resonator cone (it is generally in the range of 2"). Allowing for the amount that the resonator cone is recessed into the top (usually about 1/8" to 1/4"), add that to the depth figure for the cone (usual total 2 1/4"). Add extra 1/2" for clearance and measure down from the top of the instrument about 2 3/4".

3) Drill a pilot hole through the end block approximately 3/16" in diameter in the area you wish to place the end pin jack.

4) Using a fluted burr, chamfer the edges of the hole so that you will not damage the finish of the instrument when you use the larger sizes of bits required.

5) Drill through the guitar end block using a 3/8" bit and re-chamfer the hole. Repeat drilling with a 31/64" bit to complete the drilling operations.

7) Remove the Outer strap button, and the small nut and washer from the endpin jack or preamp. Reach inside the instrument and poke the endpin jack part through the drilled hole in the end block. The jack should protrude approximately 5/16" outside the guitar. Reinstall the flat washer and small nut.

8) Insert a small allen wrench or other small round (like a drill bit) through the 2 holes in the end of the endpin jack to keep the jack assembly from rotating; tighten the small nut.

For side jack use

1) Drill a 3/8" diameter hole in the side wall of the instrument where you want to mount the jack.

2) Remove the outer strap button, small nut and washer from the endpin jack. Reach inside the instrument and poke the jack through the drilled hole in the side. Reinstall the flat washer and nut and tighten the jack.

For hanging jack use

- 1) Drill two holes 5/32" (0.070") in diameter on the face of the instrument directly under the tailpiece. The holes should be placed about 1 1/2" from the end of the guitar so that it misses the end block.
- 2) Unsolder the pickup and mic lead wiring from the endpin jack and clip the ends of the wires clean.
- 3) Take an old guitar string and insert it down through the hole in the top. Tape the end of the pickup lead wire to the string and pull it back through the hole. Repeat for the mic lead wire. Insert both lead wires through the endpin jack cover.
- 4) For the pickup lead wire: strip about 3/4" of the black insulation, exposing the ground (-) shield wrap. Twist the wrap to form a single lead and tin it.
- 5) The inner insulated (+) wire is now exposed. Strip it back about one-quarter inch and tin it.
- 6) Solder the pickup lead wire (+) to the lug as shown.
- 7) Solder the ground (-) to the cable clamp as shown.
- 8) Repeat steps 6 and 7 for the mic lead wire.
- 9) Crimp the wire holder on the jack closed around the two lead wires. Tighten down the endpin jack cover.
- 10) Place the clip around the jack and install the clip as shown.

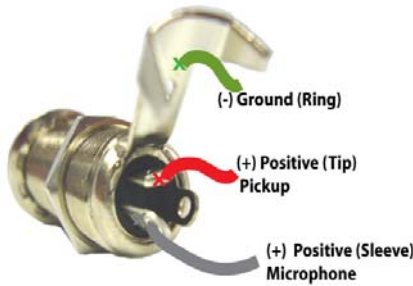

Mini Pre 2 Preamp

Preamp Configuration: as shipped, channel one will preamp the pickup sensor, while channel two will power the condenser microphone and preamp the mic signal. A black jumper is fitted over the pins at 'A' for this configuration.

Should you ever need to use the preamp with an instrument that has two pickups, the second channel can be reset for that second pickup by moving the black jumper from 'A' and fitting it over the pins at 'B'. With the jumper set at 'B', power is no longer supplied to the second channel.

1/4" Input Jack

The input jack is set up to receive a stereo TRS plug. Tip will transmit (+) from the pickup sensor to channel one. Ring will transmit (+) from the mic to channel two. Sleeve is the common ground. If you plug a mono plug into the input, the tip will transmit the (+) from the pickup sensor to channel one. Channel two will not function with a mono plug. Using a mono plug into the input will not harm the preamp but it will bring the battery down fractionally quicker than normal.

1/4" Output Jack

The output jack feeds out a mono signal only. The signal is not a balanced signal.

Input Gain Trim Pots

As shipped, channel one gain is set to approximately 15% and channel two gain is set to approximately 25%. These settings are about what the input gains might be set at for most installations. You may very well have to change these settings to suit your instrument. Important: The trim pots must be adjusted using a very small jewellers slotted screwdriver.

Setting Up The Preamp

- 1) Remove the back cover and attach a 9 volt alkaline or lithium battery (not included).
- 2) Turn the 2 external volume controls fully off, plug in the supplied stereo TRS cable to both the banjo jack assembly and the input of the Mini Pre 2.
- 3) Run a normal 1/4" cord from the Mini Pre 2 output to the input of your amp. Set the amp at a low setting.
- 4) Turn the volume control for channel one to a comfortable sound level.
- 5) Turn the volume control for channel two to a comfortable sound level.
- 6) You should now assess the relative sound levels of the pickup sensor and the microphone and adjust the input gain trim pots on the preamp circuit board as necessary.
- 7) Install the belt clip to the back cover of the preamp using the two supplied screws. Reinstall back cover.
- 8) Note that the battery within the preamp is turned on only when a plug is inserted into the output jack.

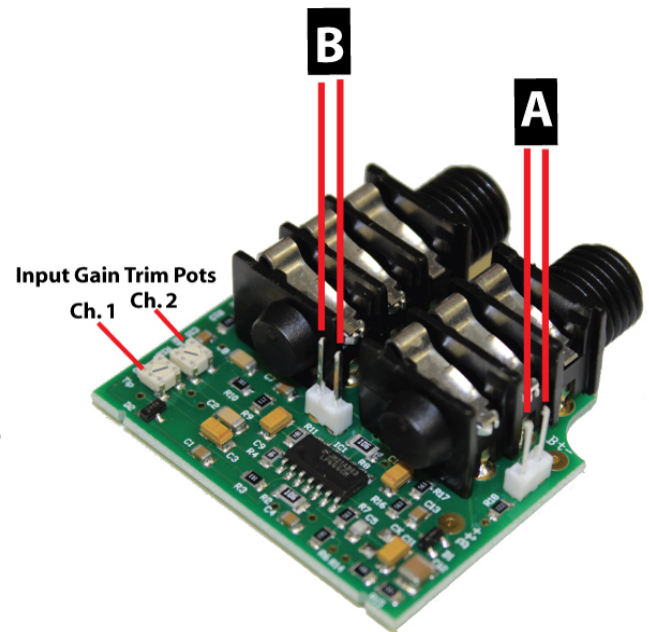

Preamp Specifications:

Input Impedance: each channel, up to 10 MOhm

Output Impedance: less than 3.5 kOhm

Input Gain: each channel 0 to 20 db via trim pots on circuit board

Battery Life: 9 volt alkaline - 1300 hours for pickup/mic configuration *Do Not Use Rechargeable Batteries*

Finishing up with the instrument

1) Prior to reinstalling the resonator assembly, the supplied wire clips should be installed in the well area to hold down any excess wire.

2) At this point it is suggested that you reinstall the resonator into the instrument (without the cover plate). Reinstall the highest treble string and lowest bass string and tune to pitch. Plug into your amp. Check that the quality of the sound is good and that string output is balanced. If everything is fine, take off the strings and remove the resonator from the instrument.

Important: Put a small bit of masking tape or scotch tape or a drop of glue on the exposed part of the mounting screw so that the nut cannot back off or rattle.

3) Reinstall the resonator assembly and the cover plate.

4) Restring, tune, and check.

Warranty

We warrant to the original purchaser that our pickups are free from defects in materials and workmanship for a period of 2 (two) years. Should a product fail to perform properly within the specified warranty period you may contact your dealer or Schatten Design for instructions. No product will be accepted for warranty return by Schatten Design without a Return Authorization number